



Société Nationale de
Certification et d'Homologation
Société à responsabilité limitée























October 14th, 2011

STATEMENT

We confirm, that the following replacement silencer type 5512, produced by SITO Gruppo Industriale S.p.A. (S.G.I.), is complying with

- the EC-Directive 97/24/EC Chapter 9 regarding permissible sound level and exhaust system

An EC type approval number has been granted by the luxembourgian Ministry for Sustainable Development and Infrastructure, department of Transport, for the following version of the above mentioned replacement silencer type:

Silencer Version	Drawing No.	Type approval number	Vehicle type	Vehicle Model
5512	5512	SGI  0497 	SAL1T – SAL1T300	PIAGGIO NTT
5512	5512	SGI  0497 	C21100 – C210 – C21000 – C220 – C22000 – C22100 – C041 – C18	PIAGGIO NRG mc2 (1999) Liquid
5512	5512	SGI  0497 	C21100 – C210 – C21000 – C220 – C22000 – C041 – C18	PIAGGIO NRG mc2 (1999) Air
5512	5512	SGI  0497 	C04000-ZAPC04000-DDZAPC1800-ZAPC2100-DDZAPC2200	PIAGGIO NRG mc2 ('98)
5512	5512	SGI  0497 	C04100-ZAPCO4000-DDZAPC1800-ZAPC2100-DDZAPC2200	PIAGGIO NRG mc2 ('97)
5512	5512	SGI  0497 	C2200 – ZAPC220-21	PIAGGIO NRG mc2 EXTREME
5512	5512	SGI  0497 	SAL1T (NRG) – SAL1T022	PIAGGIO NRG
5512	5512	SGI  0497 	TEC1T – TEC2T	GILERA TYPHOON
5512	5512	SGI  0497 	C48 var. 1 ver.00	GILERA TYPHOON 50
5512	5512	SGI  0497 	TEC1T	GILERA STORM
5512	5512	SGI  0497 	C11100 – ZAPC11000	PIAGGIO ZIP SP



Gilles AST
Expert Technique

Adresse:
BP 23
L-5201 Sandweiler

Siège social:
11, route de Luxembourg
L-5230 Sandweiler

Capital social: 3.500.000 €
R.C. B 27180
N° TVA: LU 13770825

Tél.: (+352) 35 72 14 - 250
Fax: (+352) 35 72 14 - 244
E-mail: info@snch.lu
Home page: www.snch.lu



9932920

Solo per - only for - Seulement pour -
Nur für - Sólo para:
NRG=mc2 '99 e NRG=mc2 '98 DD
distanziale/Shim/espaceur/espaciador/
Abstandhalter
Ø20xØ8,5x40

Solo per - only for - Seulement pour
- Nur für - Sólo para:
NRG=mc2 '99 e NRG=mc2 '98 DD

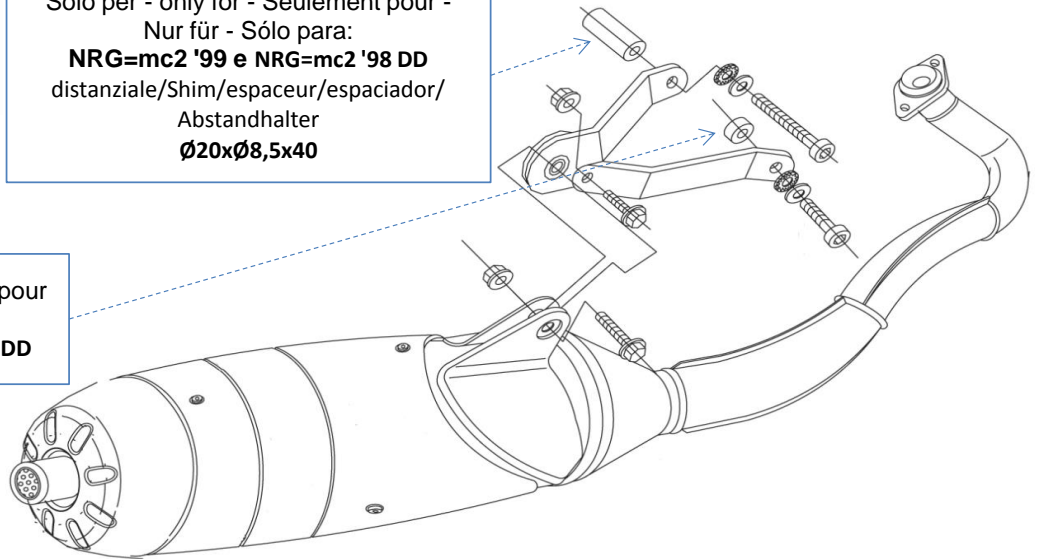

RULLI E MOLLE - ROLLERS AND SPRINGS - MASSELOTTES ET RESSORTS - ROLLEN UND FEDERN - RODILLOS Y MUELLES

RULLI: GILERA TYPHOON-STORM : Art. 4646 gr. 5,5 - **PIAGGIO NRG=mc2 ('98) - NRG=mc2 ('99 Liquid cooled) - GILERA TYPHOON 50 ('09): Art. 4659 gr. 4,8 - PIAGGIO NRG=mc2 - ZIP SP - NRG=mc2 ('99 Air cooled)**

PIAGGIO NRG-NTT: Rulli originali

ROLLERS: GILERA TYPHOON-STORM : Art. 4646 gr. 5,5 - **PIAGGIO NRG=mc2 ('98) - NRG=mc2 ('99 Liquid cooled) - GILERA TYPHOON 50 ('09): Art. 4659 gr. 4,8 - PIAGGIO NRG=mc2 - ZIP SP - NRG=mc2 ('99 Air cooled)**

PIAGGIO NRG-NTT: Original Rollers

MASSELOTTES: GILERA TYPHOON-STORM : Art. 4646 gr. 5,5 - **PIAGGIO NRG=mc2 ('98) - NRG=mc2 ('99 Liquid cooled) - GILERA TYPHOON 50 ('09): Art. 4659 gr. 4,8 - PIAGGIO NRG=mc2 - ZIP SP - NRG=mc2 ('99 Air cooled)**

PIAGGIO NRG-NTT: Masselottes original

RODILLOS: GILERA TYPHOON-STORM : Art. 4646 gr. 5,5 - **PIAGGIO NRG=mc2 ('98) - NRG=mc2 ('99 Liquid cooled) - GILERA TYPHOON 50 ('09): Art. 4659 gr. 4,8 - PIAGGIO NRG=mc2 - ZIP SP - NRG=mc2 ('99 Air cooled)**

PIAGGIO NRG-NTT: Rodillos original

ROLLEN: GILERA TYPHOON-STORM : Art. 4646 gr. 5,5 - **PIAGGIO NRG=mc2 ('98) - NRG=mc2 ('99 Liquid cooled) - GILERA TYPHOON 50 ('09): Art. 4659 gr. 4,8 - PIAGGIO NRG=mc2 - ZIP SP - NRG=mc2 ('99 Air cooled)**

PIAGGIO NRG-NTT: Rollen original

**DISEGNO TECNICO RULLI E MOLLE - TECHNICAL DRAWING ROLLERS AND SPRINGS
CROQUIS TECHNIQUE MASSELOTTES ET RESSORTS - TECHNISCHE ZEICHNUNG ROLLEN UND FEDERN
DISEÑO TÉCNICO RODILLOS Y MUELLES**

FIGURA 1

- * Battuta rullo
- * Roller beat
- * Retour plastique
- * Anschlag der rolle
- * Batiente de rodillo



FIGURA 2

Senso di rotazione
Clock-wise rotation
Sens de rotation
Drehrichtung
Sentido de rotación

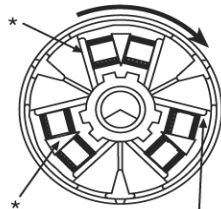

- * Battuta rullo
- * Roller beat
- * Retour plastique
- * Anschlag der rolle
- * Batiente de rodillo

MOLLE DA SOSTITUIRE - SPRINGS TO BE REPLACED
RESSORTS À REMPLACER - ZU ERSETZENDE FEDER
MUELLES PARA SUSTITUCIÓN

FIGURA 3

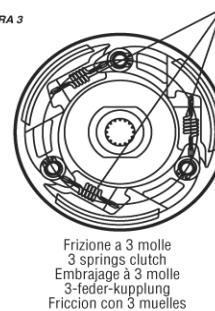

Frizione a 3 molle
3 springs clutch
Embrajage à 3 molle
3-feder-kupplung
Friccion con 3 muelles

FIGURA 4

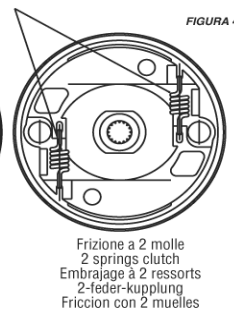

Frizione a 2 molle
2 springs clutch
Embrajage à 2 ressorts
2-feder-kupplung
Friccion con 2 muelles

VISTA DAL LATO INTERNO - VIEW FROM THE INNER SIDE
VUE DE L'INTERIEUR - ANSICHT VON INNENSEITE
VISTA DESDE EL LADO INTERIOR

LO9932920